

V800 AS

AUTOMATIC SIDE SEAM SERGING MACHINE

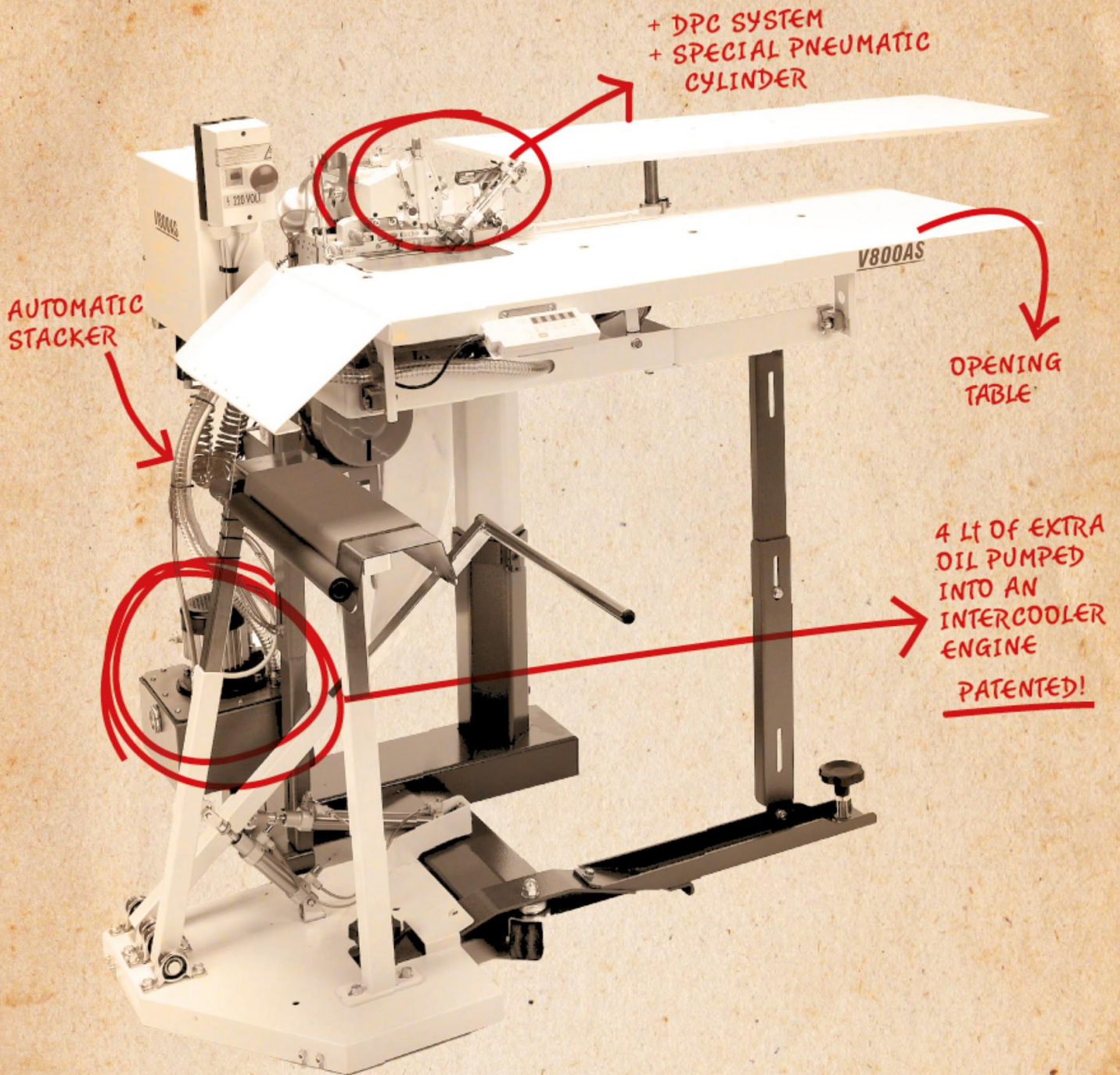

Equipped with a super fast Yamato sewing head fully made in Japan, the V800AS is a 2 needle, 4 thread overlock unit that runs at 6300 rpm (maximum speed 7000 rpm).

Developed with the latest technical solutions, this unit guarantees super high sewing performances, flexibility and an incredible stitching quality, besides long lasting life of its parts and components.

TECHNICAL FEATURES:

The innovative and PATENTED air-assisted transport system allows to stitch ANY kind of fabric, from light to heavy, stretch or double stretch, besides being the first and the only serging unit which can sew on the back panel with the back yoke already joint, thanks to our automatic and PATENTED back yoke joint detector!
The V800 AS presents amazing and patented new solutions based on our statement "BUILT TO LAST" or rather: 4 litres extra oil, forced oil device with inter cooler pump (patented), 100% cut scraps vacuum device, special cutting system device with HSS blades (patented) provided with vacuum and sensor which allow the machine to work continuously, long lasting blade +50% and threads saving over +70%. An extra Pneumatic cylinder assists the cutting device.

PERFORMANCE

Sewing head made in Japan by Yamato Company

Standard sewing head features:

2 needle overlock unit standard

Speed: 6300 rpm (Max Speed 7000 rpm)

Overlock width 6.0 mm up to 9.6 mm

Stitch per Inch: up to 30 (spi)

100% cut scraps vacuum device

4 litres extra oil, forced oil device with intercooler pump (patented)

Special guide device with automatic back yoke joint detector

Special guide device with manual regulation for different fabric thickness

Special cutting device HSS blade (patented) with vacuum and photocell, long last cutter blade +50% *
threads saving over +70%**

Extra Pneumatic cylinder assistance on the cutting device

Directional forced air device, not required any hand touch by the operator during the operation.

